



(LOZKO VENEČKA)

OR

Note:

- Read Instructions carefully.
- Carefully identify each component especially those that are similar.
- Separate and identify each component from the hardware pack and rest each one in its proper location before fastening.
- Do not over tighten the screws or bolts when assembling.



2 Persons

TOOL REQUIRED

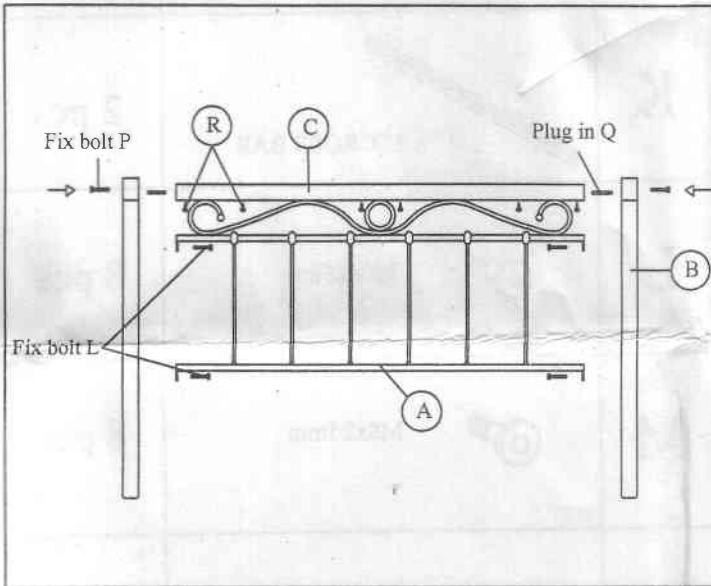

Step 1 Assemble the bed frame component as shown.

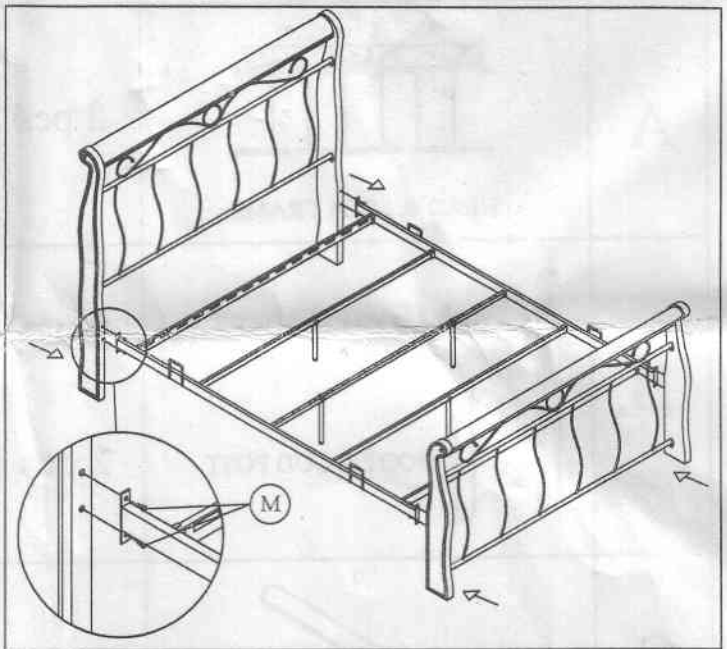

Step 4 Assemble bed base into bed frame and tighten all bolts.

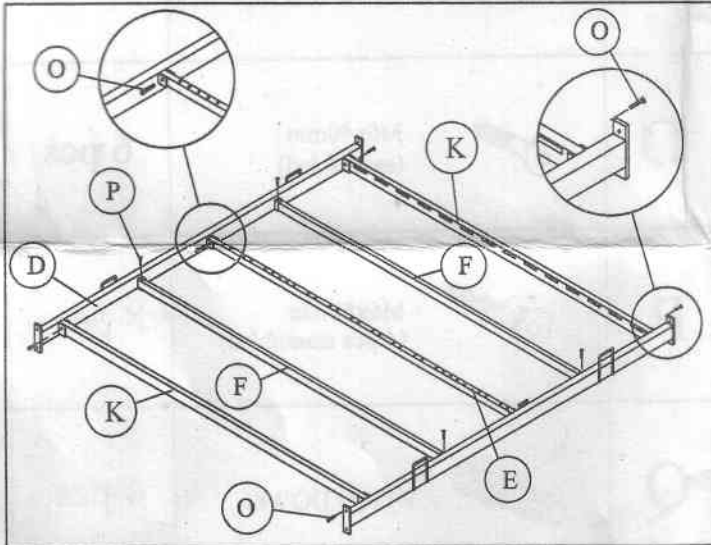

Step 2 Fix both side rails and cross bar E with bolt O as above diagram. Put cross bar F into side rail and fix in bolt P. After that put end cross bar K to the end of side rail and tighten with bolt O.

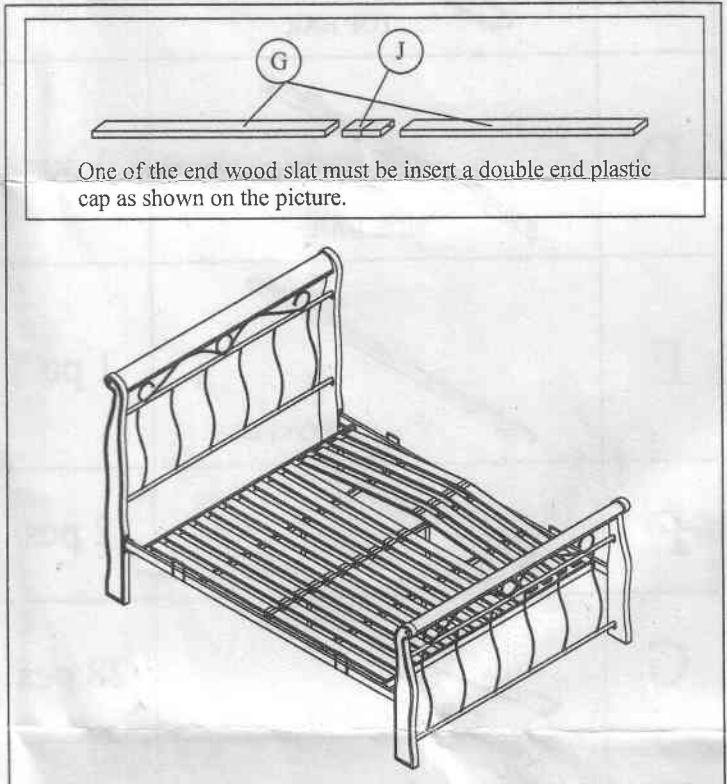



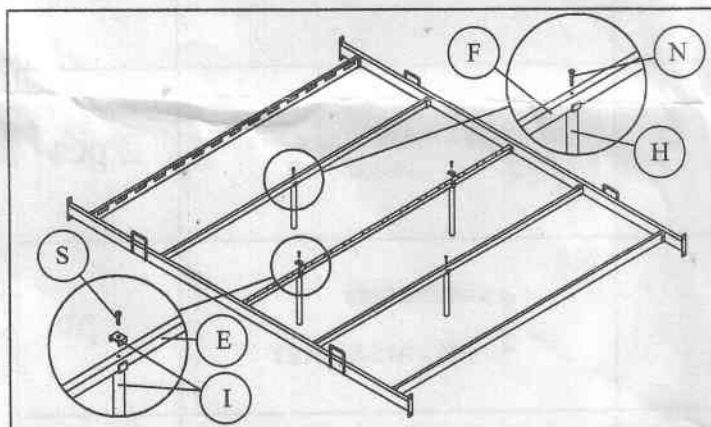







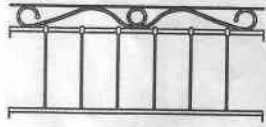
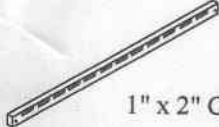



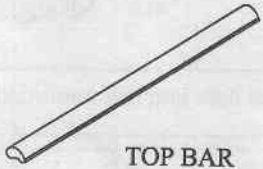

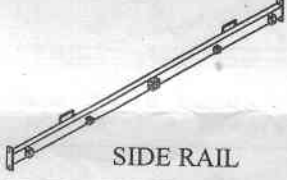
Step 5 Once wood slats have been inserted into the plastic caps, fix one end of wood slat into the hole of end cross bar K and the other end to the other end cross bar. After that fix the plastic cap to the center cross bar by pressing it accordingly to the default holes. Ensure the plastic cap's pin aimed to the hole.

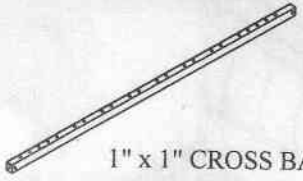
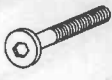
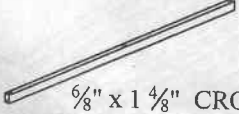

Step 3 Fix bed support legs as shown on the picture.

Please follow our Assembly Instruction procedure for easier assemble.

PART & HARDWARE LIST FOR B1.6-832W-UNS-KD (LOZKO VENEJA)

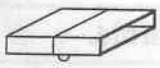
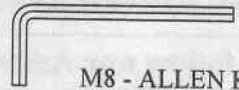
NO	PART	QTY	NO	PART	QTY
A	 HEAD & FOOT FRAME	2 pcs	K	 1" x 2" CROSS BAR	2 pcs
B	 HEAD WOOD POST	2 pcs	L	 M6x25mm	8 pcs
	 FOOT WOOD POST	2 pcs	M	 M8x25mm	8 pcs
C	 TOP BAR	2 pcs	N	 M6x45mm (assembled)	2 pcs
D	 SIDE RAIL	2 pcs	O	 M6x40mm (assembled)	6 pcs
E	 1" x 1" CROSS BAR	1 pc	P	 M6x50mm (4 pcs assembled)	8 pcs
F	 $\frac{3}{8}$ " x $1 \frac{1}{8}$ " CROSS BAR	2 pcs	Q	 WOOD DOWEL	4 pcs
G	 WOOD SLAT	28 pcs	R	 CHIPBOARD SCREW 16mm	12 pcs
H	 SHORT SUPPORT LEG	2 pcs	S	 M8x40mm (assembled)	2 pcs
I	 LONG SUPPORT LEG	2 pcs		 M6 - ALLEN KEY	1 pc
J	 Double end plastic cap	14 pcs		 M8 - ALLEN KEY	1 pc