

Zde si můžete změřit kování k přesnému určení typu dle velikosti. Všechny rozměry jsou uvedeny v milimetrech.
 Here, you can measure the furniture hardware to recognise a certain part according to its size. All proportions are in millimetre.
 Hier können Sie die Schrauben zur besseren Identifizierung nachmessen (alle Maßangaben in mm).
 Tu można zmierzyć okucie w celu dokładnego przeznaczenia typu wg wielkości. Wszystkie wymiary podane są w milimetrach.
 Itt lemérheti a vasalatot a típus méret szerinti pontos meghatározásához. Valamennyi méret milliméterben megadva.
 Tukaj lahko spremenite okovje in natančno določite tip in velikost. Merske enote vseh dimenzij so milimetri.
 Tu si môžete odmerať kovanie na presné určenie typu podľa veľkosti. Všetky rozmery sú uvedené v milimetroch.

60 min.

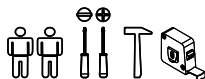

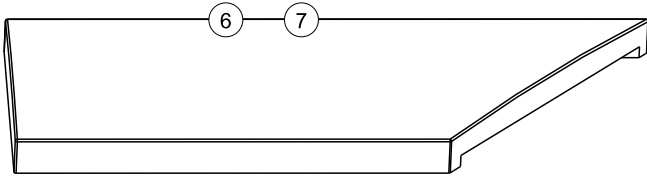

1575 mm - 2200-9000
1725 mm - 2202-9000
1875 mm - 2204-9000

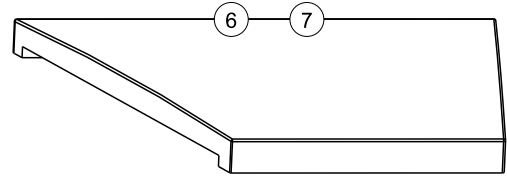

1175 mm - 2200-9001
1325 mm - 2202-9001
1475 mm - 2204-9001

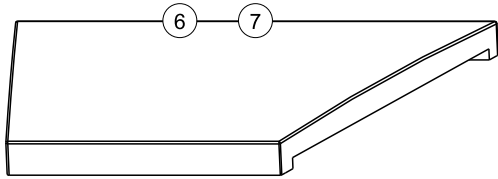

1175 mm - 2201-9001
1325 mm - 2203-9001
1475 mm - 2205-9001

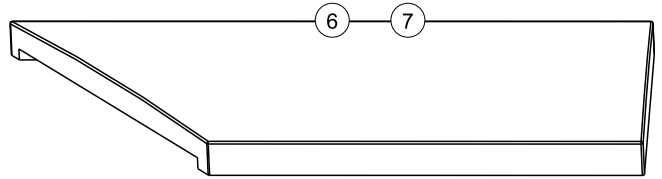

1575 mm - 2201-9000
1725 mm - 2203-9000
1875 mm - 2205-9000

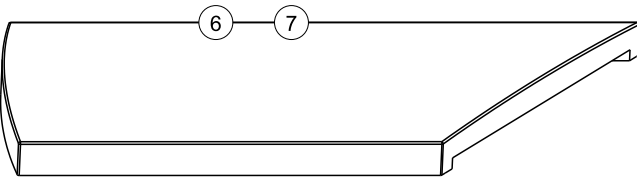

1585 mm - 2218-9000
1735 mm - 2220-9000
1885 mm - 2222-9000

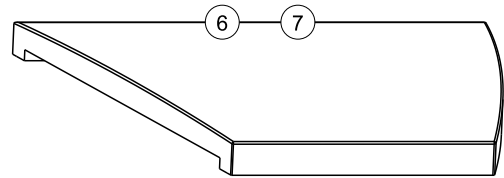

1185 mm - 2218-9001
1335 mm - 2220-9001
1485 mm - 2222-9001

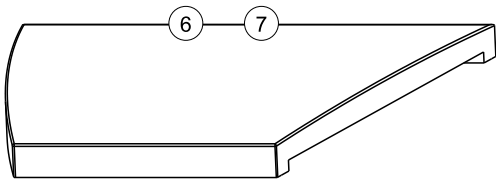

1185 mm - 2219-9001
1335 mm - 2221-9001
1485 mm - 2223-9001

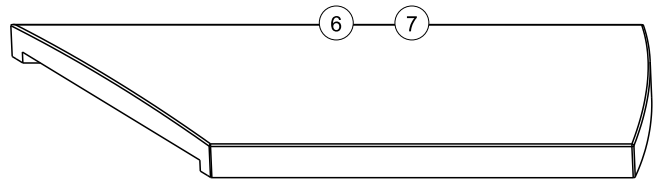

1585 mm - 2219-9000
1735 mm - 2221-9000
1885 mm - 2223-9000

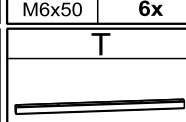
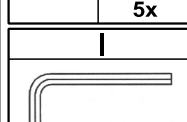
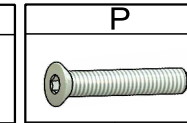
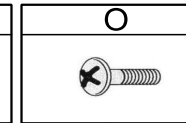
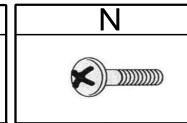
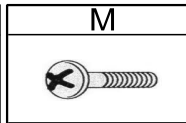
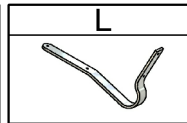
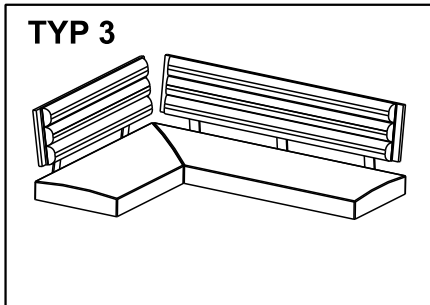
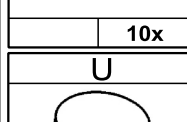
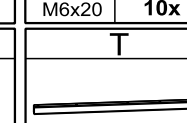
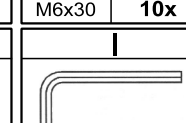
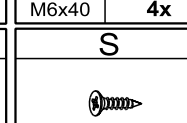
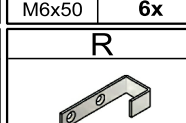
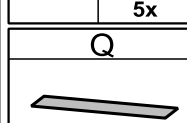
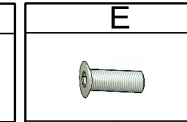
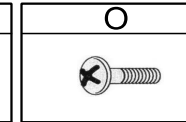
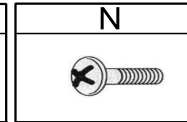
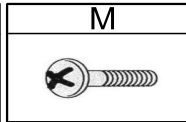
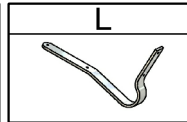
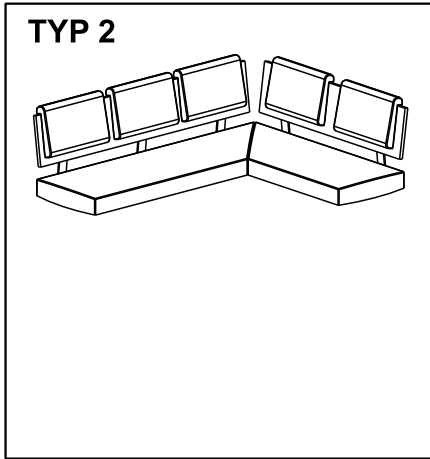
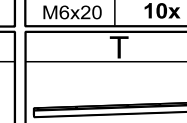
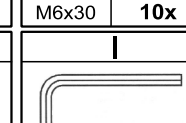
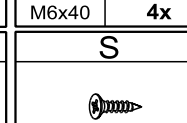
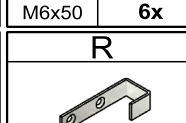
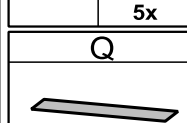
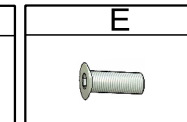
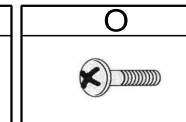
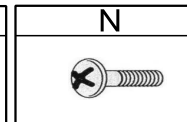
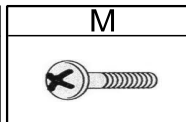
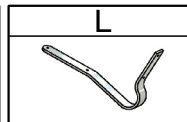
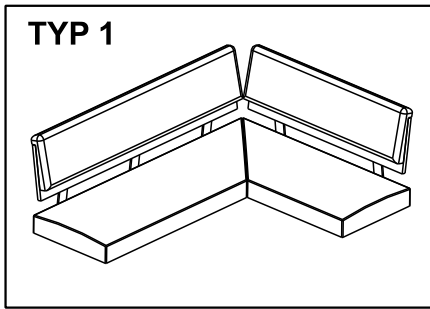
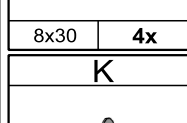
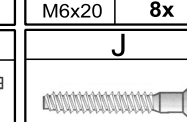
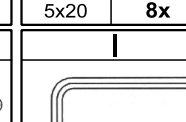
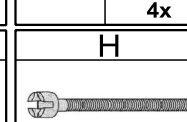
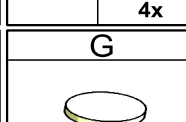
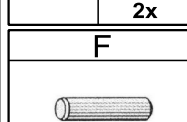
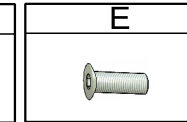
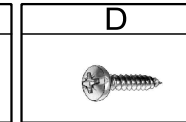
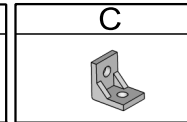
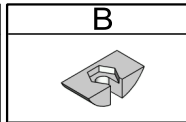
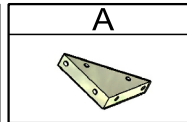
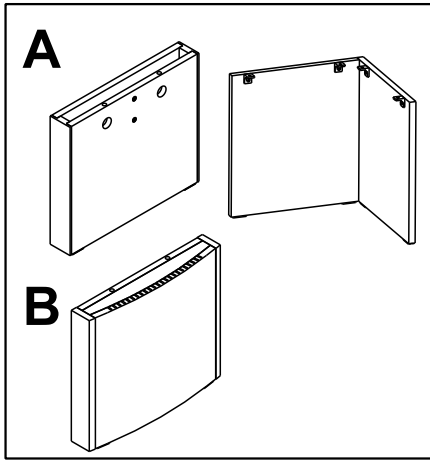

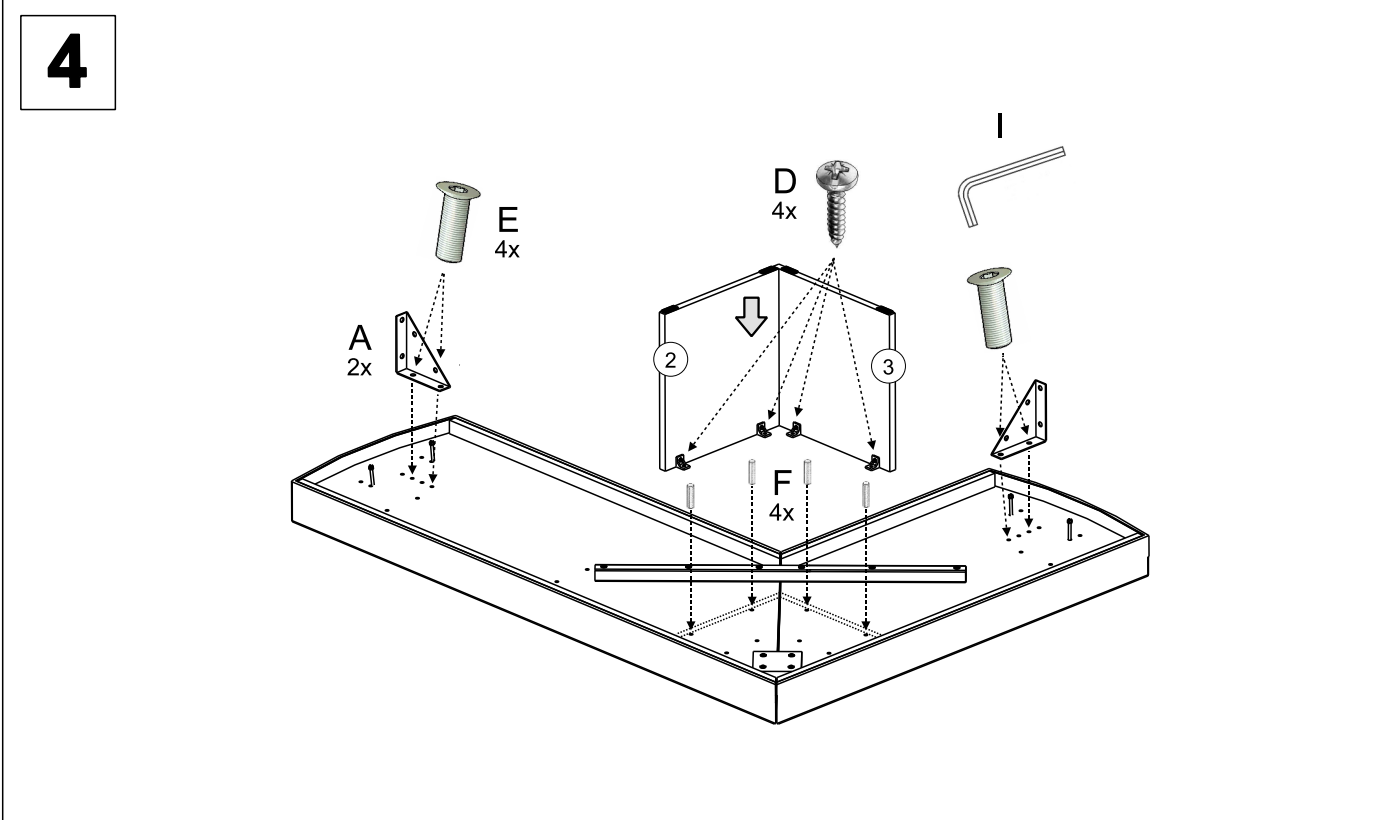
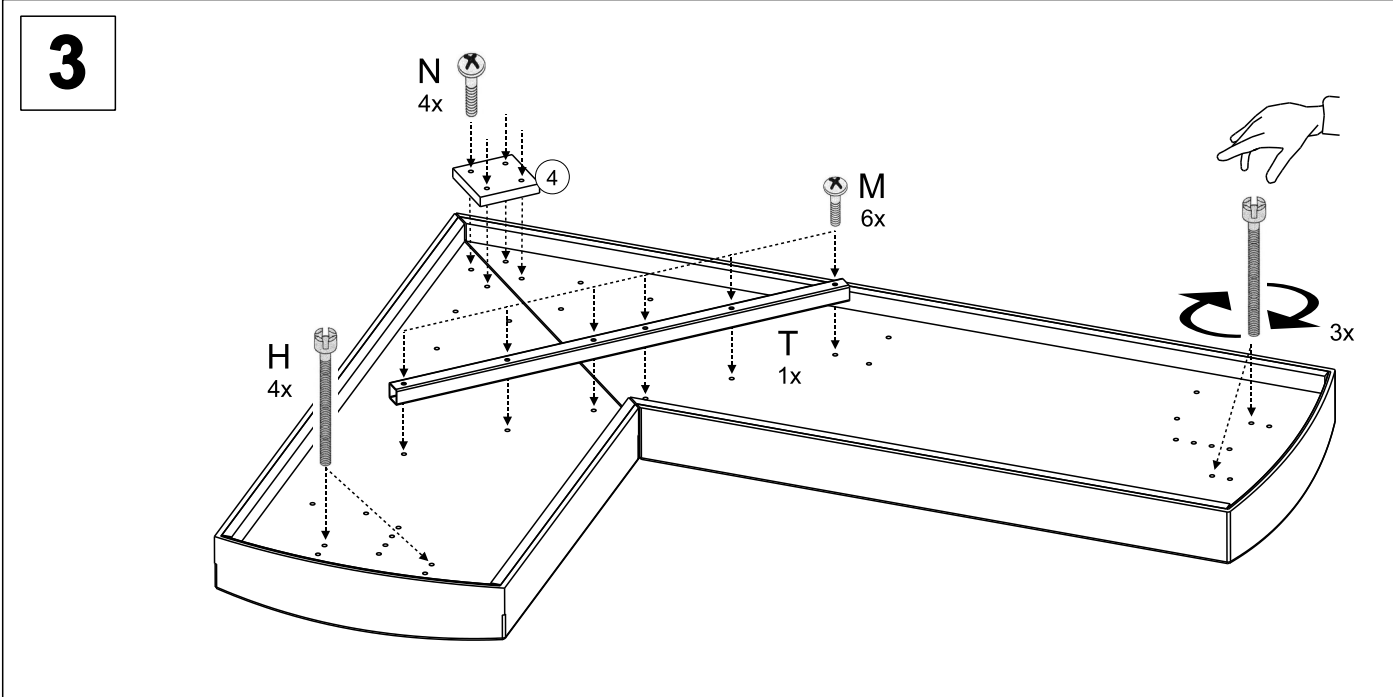
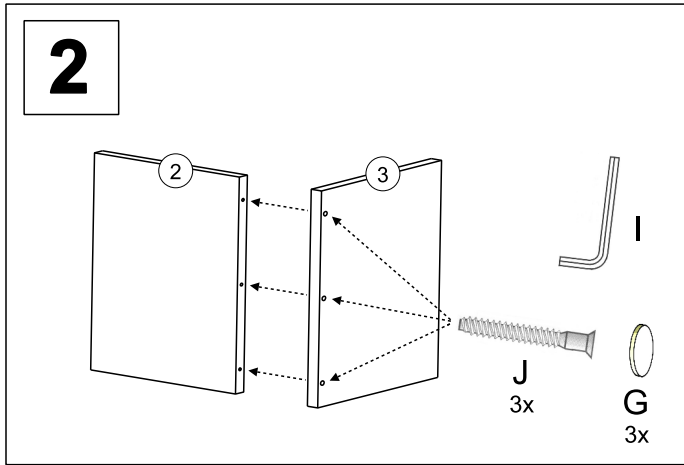
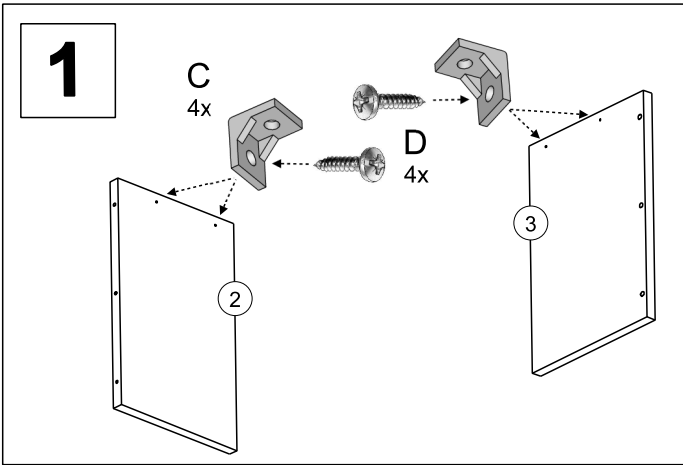

5

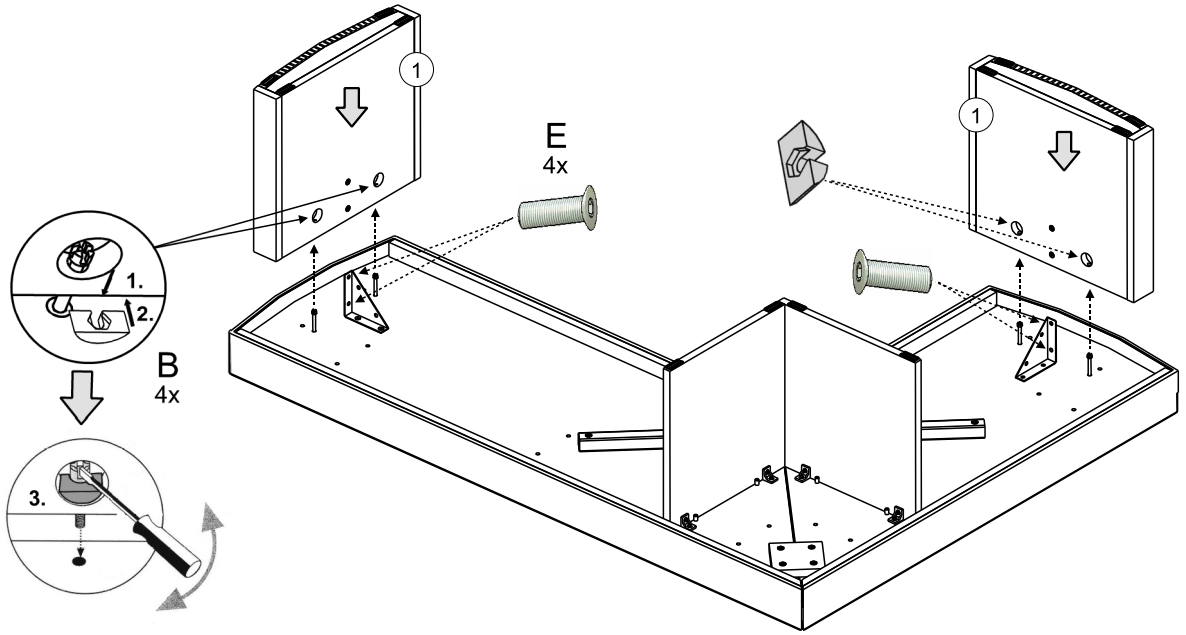

6

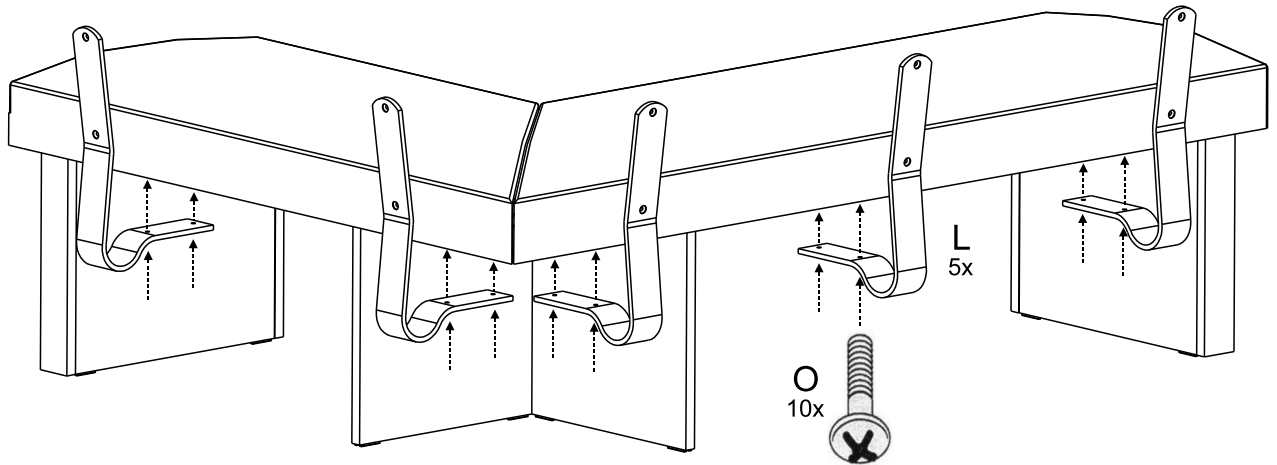

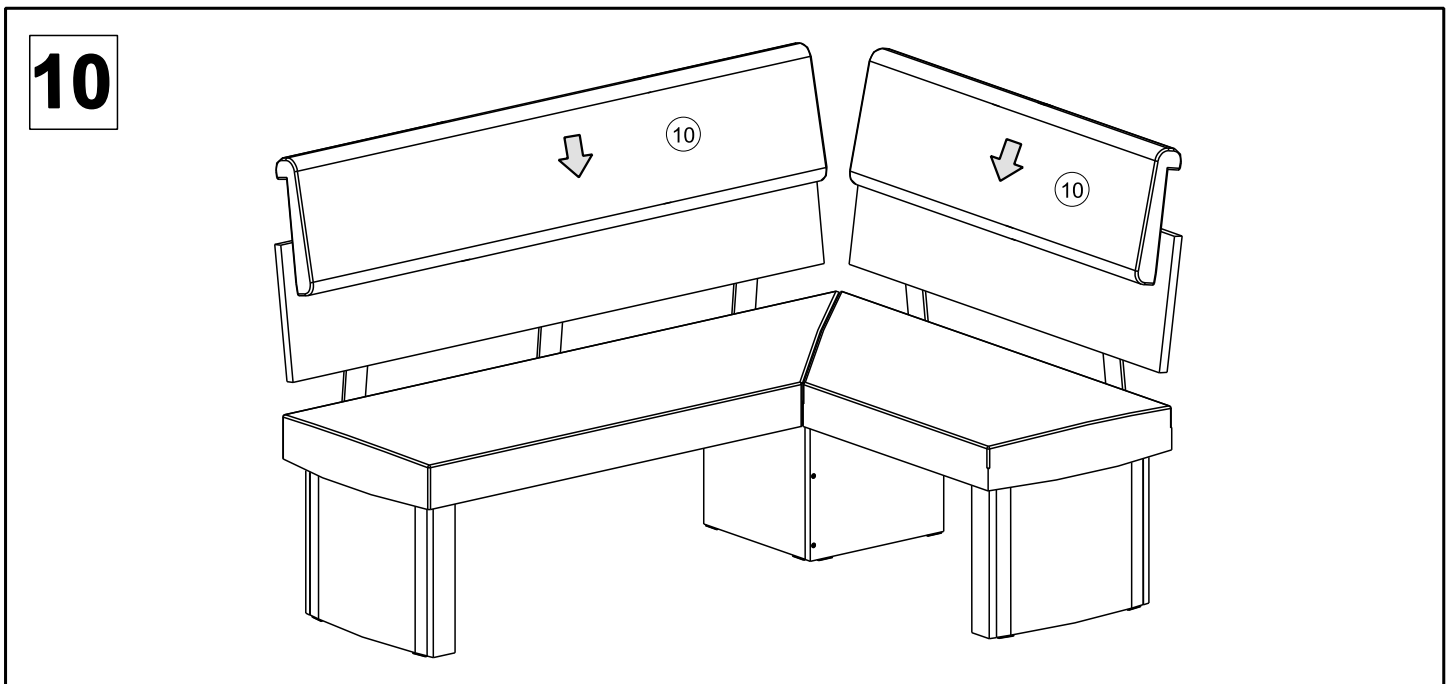
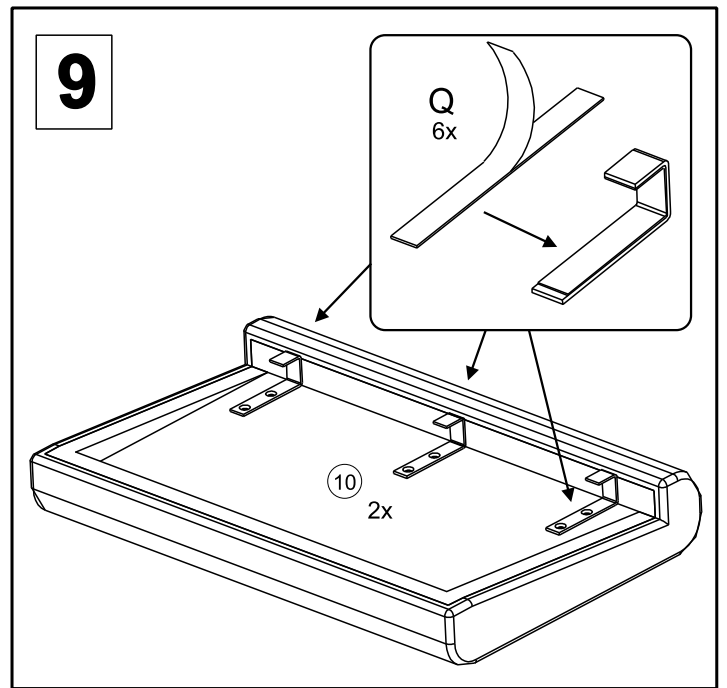
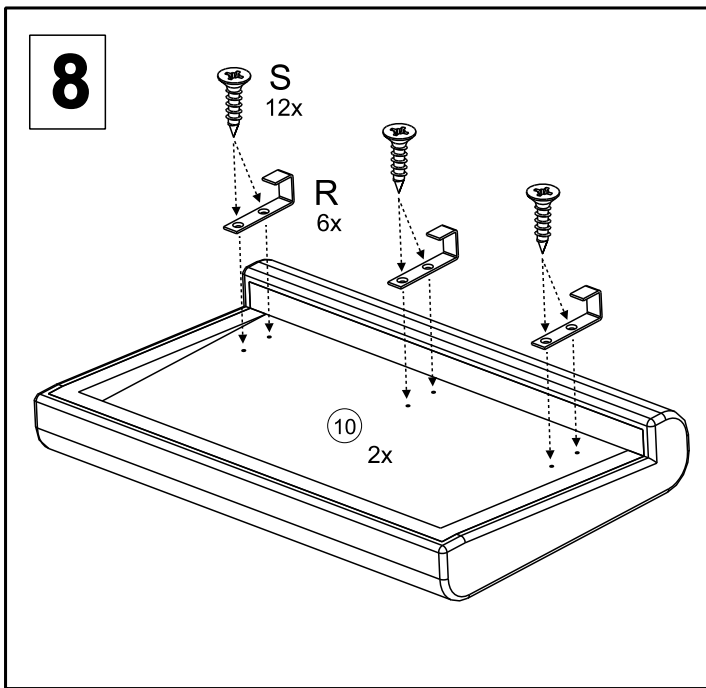
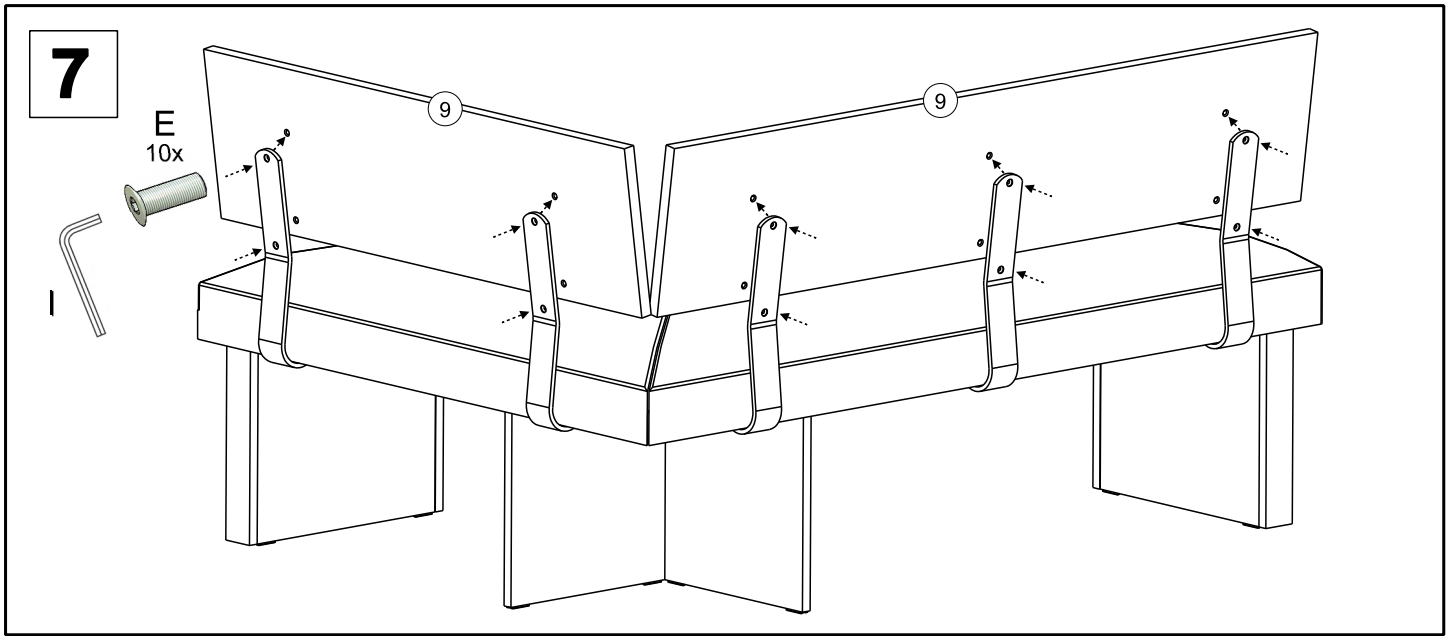

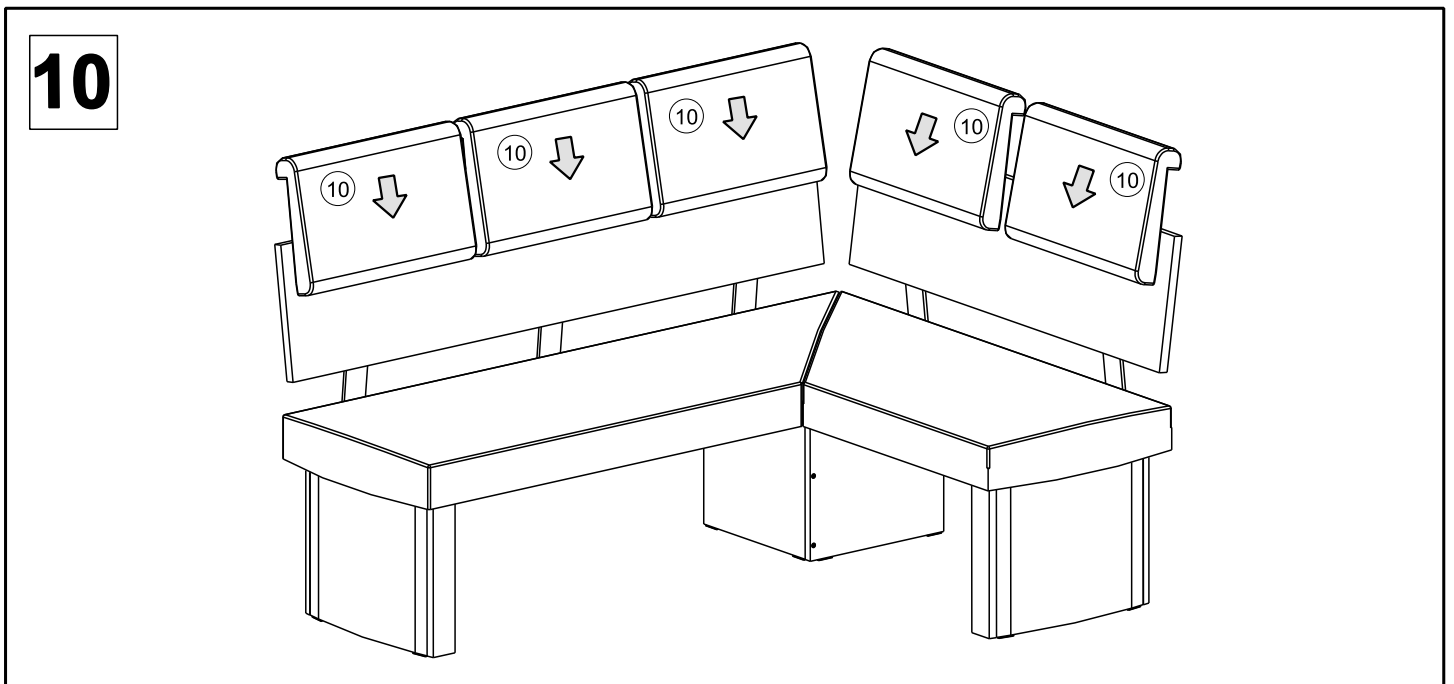
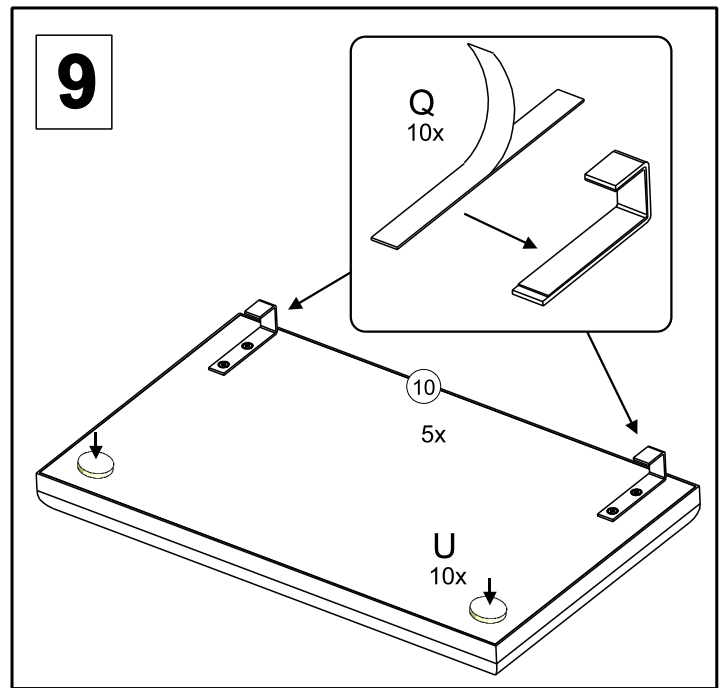
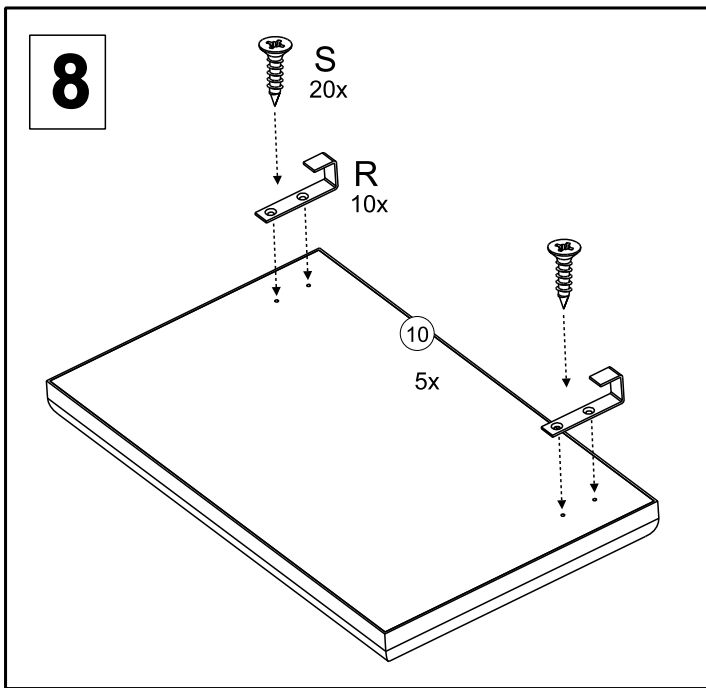
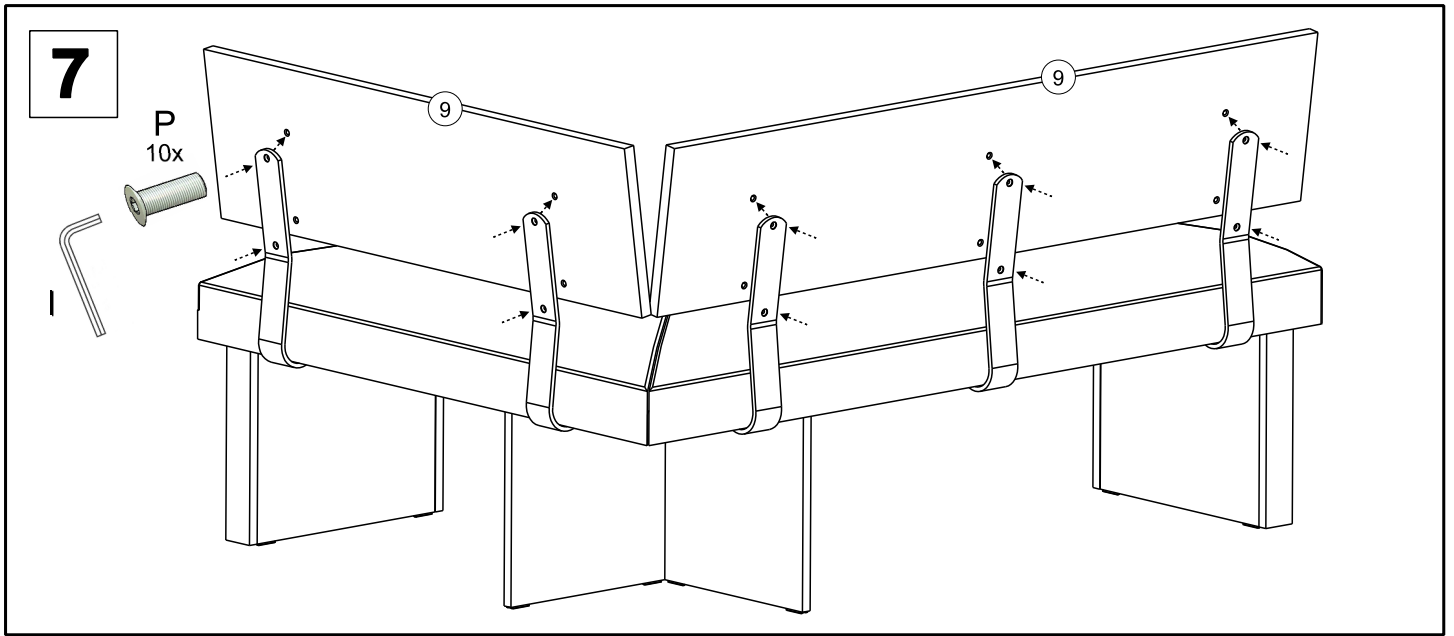

7

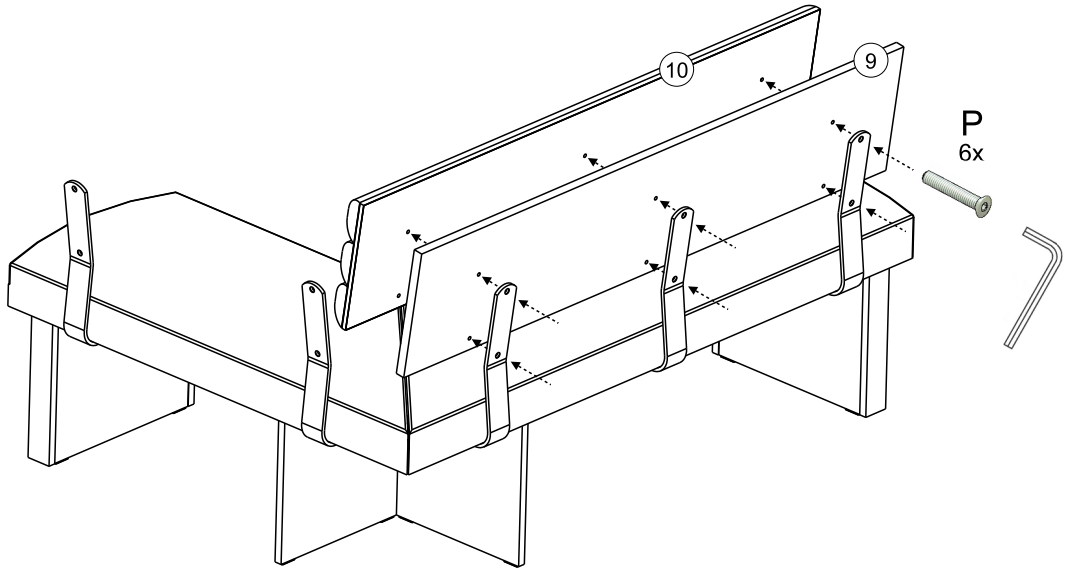

8

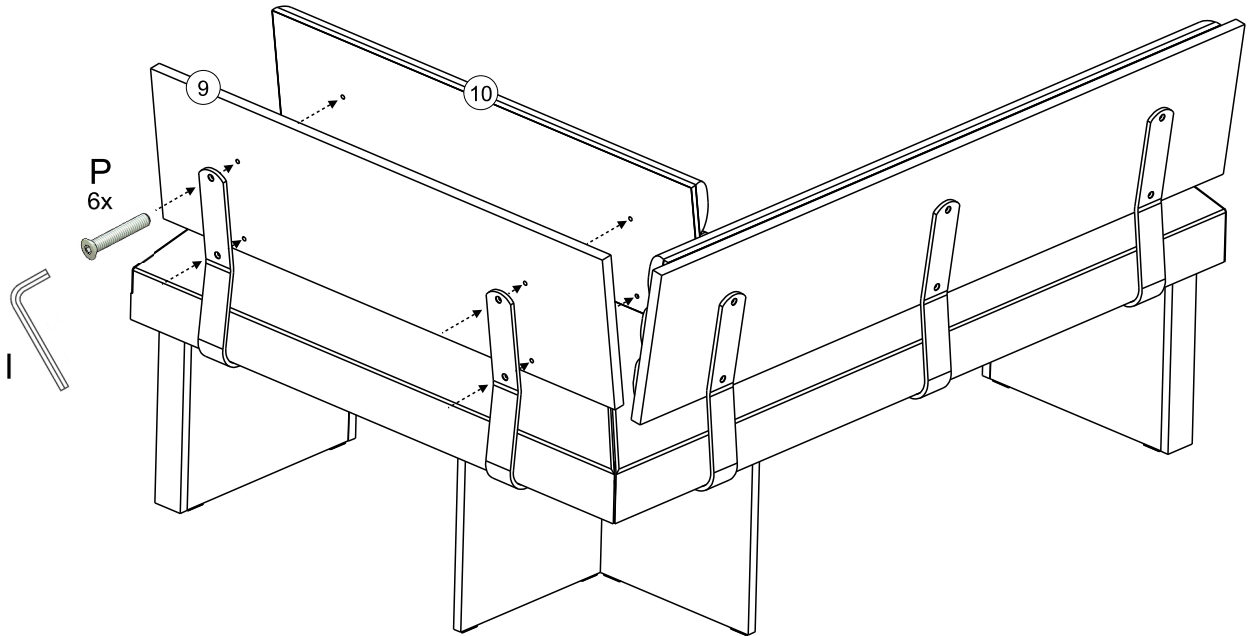

9

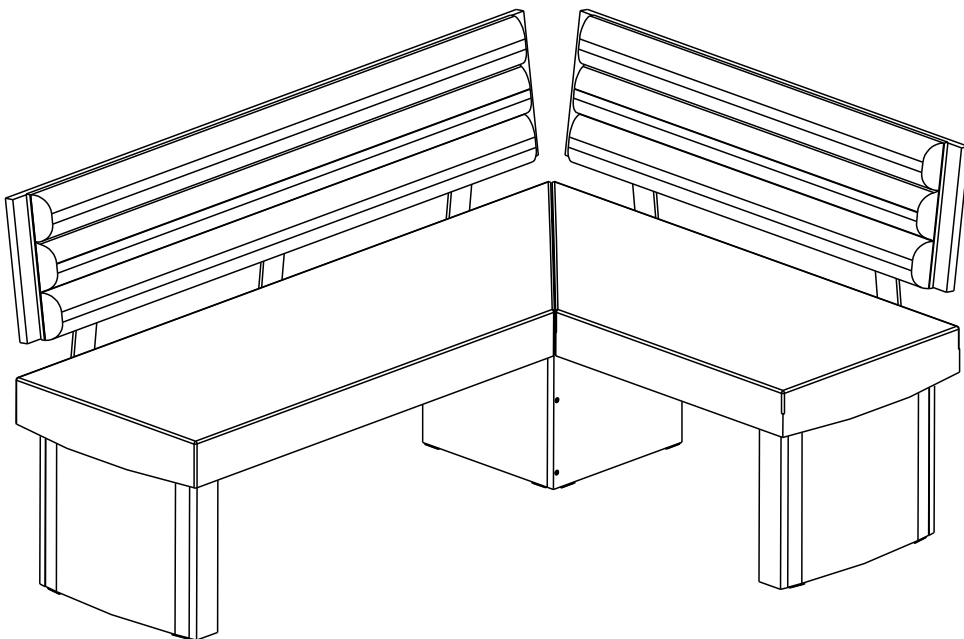

Pečujte správně o svůj nábytek!

Pěkný nábytek dělá radost, často celý život. Zde je pár tipů, jak můžete nejlépe pečovat o svůj nábytek.

Stírání prachu a vysávání děláte jako normálně. Prachovka úplně stačí na to, abyste udrželi povrch lesklý. Vězte si k tomu pokud možno hadřík bez chloupků, impregnovaný. Také starší nebo neimpregnované hadříky stírají prach, pokud použijete nábytkový lesk. Čalouněné části vysajte vhodným nástavcem (podle návodu) opatrně ve směru prachu.

Jak čistit správně nábytek!

Nepoužívejte nikdy ostré domácí čističe, odírající prostředky nebo mokré hadry.

Při lehké péči dodržujte následující tipy:

Dřevěné povrchy a části dřeva

Nábytkový lesk dejte nejlépe na prachovku a ne přímo na dřevo. Lesk odstraní lehké stíny, oživí povrchovou strukturu a vytvoří ochranný film proti ohmatání a otlakům prstů. Malé množství lesku zabrání přítom flekům.

Malé škrábance se zneviditelní tak, že použijete prostředek přímo ve směru proti škrábanci.

Umělohmotné povrchy

Tyto lehce ošetřovatelné povrchy se dají lehce očistit vlhkým ručníkem a trochou mýdla. Pouze při silném znečištění se doporučuje čistič na umělohmotné povrchy.

Lesklé kovové povrchy

K lesku těchto povrchů jsou dostačující prostředky na kovové části. Kovy jsou ošetřeny prachovkou bez chloupků.

Látky na čalounění

S ohledem na rozdílné materiály se mají u silného znečištění a fleků používat patřičné prostředky.

Odborníkem doporučené prostředky byste měli nejprve vyzkoušet na nějakém neviditelném místě.

Lehká znečištění můžete jednoduše vyčistit teplejší vodou a bílým čistým ručníkem.

Oddělatelné potahy neperte nikdy sami!

Kožené potahy

Při čištění dbejte příložených návodu.

Objednání náhradních dílů

Vážený zákazníku,

pokud je část výrobku poškozena nebo chybí, volejte prosím na servisní číslo uvedené na faktuře nebo v našich návodech.

Kód výrobku	Kostra			
	Čal			
Číslo dílce (xxxx-xxxx, xxxx-xxx)				
Počet				
Označení kování (např. B)				
Počet				



NÁBYTEK LM INTERIER

tř. Tomáše Bati 1566
Otrokovice

www.lm-interier.cz
info@lm-interier.cz

725 268 171

Otevřeno: Pondělí - Pátek 9 - 17.00
Sobota - 9 -11.00